

CONTROLLER BOARD CONVERSION KIT

Installation Instructions

Part Number: PUPKIT

The PUPKIT controller is designed to replace existing full height turnstile installations employing the Robot Industries relay controls, Burle/Philips Multi-Controller, The Philips STGXXX PLC controller and the Tomsed 8.00 and 8.03 series of controllers.

IMPORTANT SAFEGUARDS

READ CAREFULLY

CAUTION: This upgrade installation suggests you to have installed the newer type solenoids. Older solenoids will have both wires the same color. The newer type will have a red and a black wire. **Be sure that any existing solenoids are not defective. Use of defective solenoids may cause a malfunction and will void all warranties.**

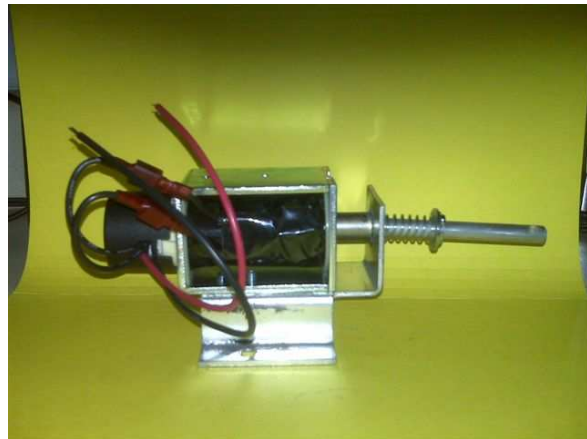
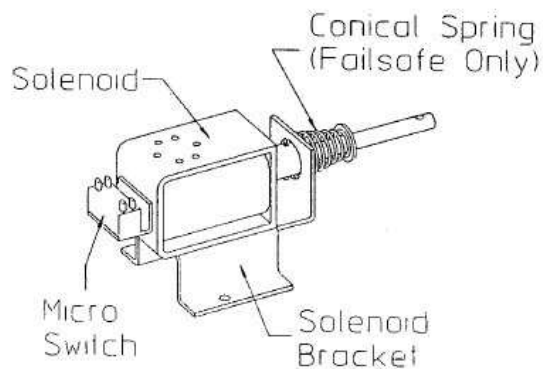

Older Style with Microswitch at Back ----- New Style with Red & Black Wires

If your system has a loading resistor (looks like a strip heater) connected across the old transformer's red and yellow wires, it will no longer be required.

Always disconnect power supply prior to servicing turnstiles

Heed Warnings – All warnings on the unit and in the operating instructions should be adhered to.

Revision Note: *With this revision, the notations CW and CCW have been replaced with the more meaningful terms ENTRY and EXIT.*

1. Turn off electrical power **before** removing cover.
2. From the secured side (inside) of the turnstile, remove the cover access panel (above).
3. Remove all wiring from existing controller board, making sure to tag wires for identification.
 - A. Determine which card reader wires, indicator lamps and solenoids will be designated for entry and for exit and mark accordingly. If you have solenoids with a red(+) and black wire(-), be sure to observe proper polarity when reconnecting to the new Control Board Subassembly.

B. Red and Green indicator lamps will no longer be connected through the old locking bar micro-switches. They will now be connected to points on the Control Boards. If you have LED type lamps, be sure to observe polarity.

C. Identify the Rotation Switch and the Limit Switch and mark each set of wires accordingly.

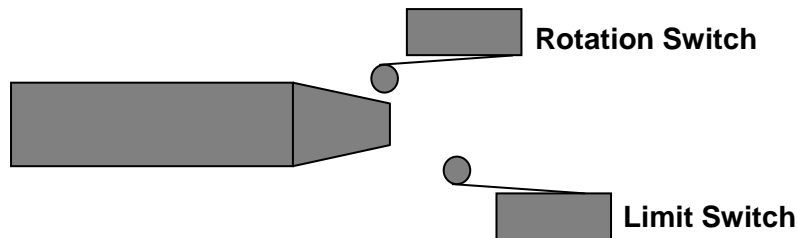

4. Remove screws attaching controller board to mounting plate. Remove screws holding existing power transformer

5. Remove existing controller board and power transformer and bridge rectifier. **Retain the transformer mounting plate with the 115VAC terminal board** as you will need to use it to extend the 115VAC wires to reach the new Control Board Subassembly.

6. Mark the position of the four corner standoffs of the mounting plate. These will be used to mount the new Control Board Subassembly. Remove all remaining standoffs.

7. Mount the new control board subassembly using the four marked holes with four screws and nuts with lock washers. Tighten securely.

8. Rewire the turnstile according to enclosed wiring diagram. **Pay particular attention to the routing of wires. The extended 115VAC wires should be routed as far away from the remaining wires as possible. Dress all wiring in a neat and secure manner to avoid contact with any moving part or mechanism.** Please note that all microswitches and card readers must be configured as Normally Open devices.

9. Important: Be sure to connect the solenoid wires according to their proper polarity and function: Fail-Lock or Fail-Safe

How do I know if a particular direction is Fail-Lock or Fail-Safe (Fail Unlocked)?

Turn off all power to the turnstile. If the turnstile does not rotate, then that direction is Fail-Lock. If the turnstile does rotate, then that direction is Fail-Safe.

Prior to Applying Power

Check to ensure all wire connections to both the power and controller are secure. Make sure the turnstile is grounded and the grounding screw is tightened.

10. Remove tools and re-attach access panel.

11. Apply power.

12. Cycle test for proper operation a minimum of 3 times in each direction of rotation.

INSTALLATION DOs AND DON'Ts

DO..... Read all instructions thoroughly before proceeding with the installation.

DO..... Pay special attention to all referenced drawings when installing turnstile.

DON'T... Service the turnstile without turning off the power.

DON'T... Discard these instructions after installation.

Caution: Improper installation WILL VOID all warranties on this product. If you should have any questions or need more information, please contact our Technical Support Department.

Special wiring notes concerning the Robot Industries and Robot/Burle relay logic:

- 1- Early Robot and Robot/Burle turnstiles employed discrete relay logic. You will need to completely remove many of these components including power supply.
- 2- You should have remaining:
 - a. A pair of wires for each card reader output.
 - b. 2 solenoids; one for entry and one for exit if so equipped.
 - c. 2 microswitches; either 1 Rotation & 1 Limit Switch or 2 Rotation Switches(see note 5)
 - d. Directional lamps if so equipped.
- 3- Some of these turnstiles employed Normally Closed configured microswitches. You will need to reconfigure them as Normally Open.
- 4- In some instances, card reader outputs are configured as Normally Closed. Insure that they are configured as Normally Open for this upgrade.
- 5- Some early Robot turnstiles have a different configuration of microswitches and means of activation than shown on the previous page. This early configuration can be identified as having microswitches with a hinged roller arm permitting activation in one direction only. Insure both microswitches are configured as Normally Open and connect both, in parallel, across Pupkit terminals 7 & 8. In addition place a wire jumper between terminals 5 & 7.



Earlier design employing hinged roller microswitches – Ratchet Activated

Hinged Roller (53-520)



Fixed Roller (21-113)

The PUPKIT is totally symmetrical in functional operation. The description of entry functions is applicable to exit functions.

Operation:

- 1- A momentary (less than 3 seconds) contact closure across the card reader input permits one entry only.
- 2- In normal operation, the first direction activated will lock out the other direction
- 3- If no one enters in 10 seconds, the controller resets.
- 4- An extended (3 seconds or greater) contact across the card reader input, places that direction in override permitting free passage.
- 5- If a direction has been placed in override, the other direction is not locked out and is available for use.
- 6- PLC inputs 5 & 6 are new functions. These are "Instant Override". A contact closure between PLC input 5 and any even terminal board number will place entry in free passage. PLC input 6 functions similarly for exit.
- 7- If you have a PUPKIT/MD there will be no "Instant Override" feature. PUPKIT/MD models are distinguished by a Firmware label on the PLC marked "Firmware Version PUP-MD" PLC input 5 is disabled. Input 6 is "Instant Reset". A contact closure between Input 6 and any even numbered terminal will cause an immediate lockdown of the turnstile. Connect the dry Normally Open momentary contact output of your Metal Detector across these terminals.

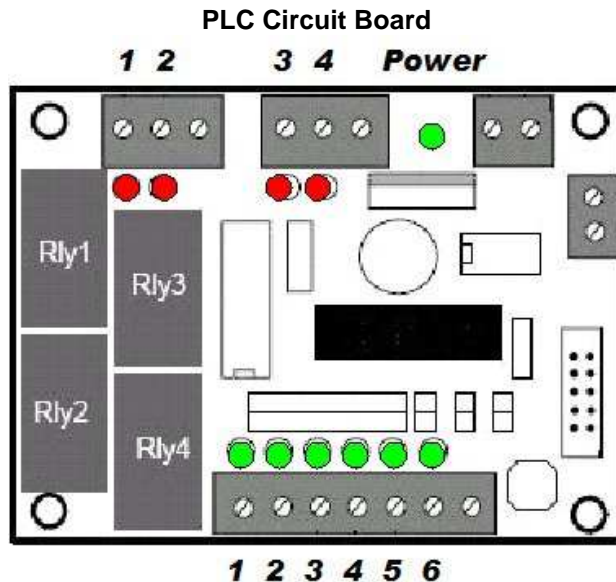

Red and Green LED indicators will be referred to by color and number. R3, for example will mean Red LED #3. Also, With the exception of the Green Power LED, Red LED's are associated with PLC outputs and Green LED's are associated with PLC inputs.

Troubleshooting - Assignments and Behavior:

Green Power LED – All circuit boards on the PUPKIT are supplied by a common 18VAC transformer. Each circuit board internally produces the DC voltage that it requires. The PLC is the last device at the end of the wiring harness to receive power. If the Green Power LED is lit, then power is being supplied to all circuit boards.

Input 1 – G1 – Entry Card Reader Input – As long as there is a closed "go" signal from your "entry" card reader system, this LED will be lit. Proper operation requires that your card reader system supply a momentary contact closure of less than 2 seconds. A contact closure greater than 3 seconds will place that direction in override.

Input 2 – G2 – Exit Card Reader Input – As long as there is a closed “go” signal from your “exit” card reader system, this LED will be lit. Proper operation requires that your card reader system supply a momentary contact closure of less than 2 seconds. A contact closure greater than 3 seconds will place that direction in override.

Input 3 – G3 – Rotation Microswitch Input – At turnstile “home” position, this LED should be off. As the turnstile approaches mid-rotation the LED should illuminate. The LED should extinguish as the turnstile enters the final stage of rotation.

Input 4 – G4 – Limit Microswitch Input – At turnstile “home” position, this LED should be off. As the turnstile is almost at mid-rotation the LED should illuminate. The sequence should be G3 first, then G4. Once past mid rotation, G4 should extinguish first followed by G3 extinguishing.

Note: The description above for G3 & G4 refers to microswitches activated by the Activation Rod aka Self Centering Plunger. For earlier Burle units with ratchet activated microswitches, G3 & G4 will operate simultaneously. Inputs 3 & 4, in this case are clockwise and counter-clockwise rotation switches. Refer to the special wiring notes for this configuration on previous pages.

Input 5 (non MD Models) – G5 & Input 6 – G6 - These are “Instant Override”. A contact closure between Input 5 and any even terminal board number will place entry in free passage. Input 6 functions similarly for exit. For MD (Metal Detector) models, there is no “Instant Override” function. Input 5 is disabled. A contact closure from your Metal Detector across Input 6 and any even numbered terminal will cause an “Immediate Reset” of any authorized passage.

Output 1 – R1 – Entry Control – This output controls the entry Turnstile Control Board (TCB). Whenever this LED is lit, the Red LED on the entry TCB will be lit as well. At that same time the entry direction solenoid will energize (if Fail-Lock) or de-energize (if Fail-Safe). R1 will be lit if a valid entry card is made, Input 1 has been held closed for more than 3 seconds (delayed override), or Input 5 is held closed (instant override).

Output 2 – R2 – Entry Direction Delayed Override – If input 1 is held closed for more than 3 seconds, R2 will illuminate indicating that the entry direction is in delayed override. R2 will not illuminate if the entry direction is in instant override. The output is not used; only the LED for troubleshooting.

Output 3 – R3 - Exit Control – This output controls the exit Turnstile Control Board (TCB). Whenever this LED is lit, the Red LED on the exit TCB will be lit as well. At that same time the exit direction solenoid will energize (if Fail-Lock) or de-energize (if Fail-Safe). R3 will be lit if a valid exit card is made, Input 2 has been held closed for more than 3 seconds (delayed override), or Input 6 is held closed (instant override).

Output 4 – R4 – Exit Direction Delayed Override – If input 2 is held closed for more than 3 seconds, R4 will illuminate indicating that the exit direction is in delayed override. R4 will not illuminate if the exit direction is in instant override. The output is not used; only the LED for troubleshooting.

Entry & Exit Control Boards:

These boards are responsible for voltage conditioning, overload protection, inductive arc suppression and solenoid control. They take their control from the output of the PLC at terminals V & 0. Although there are 3 LED's and 3 chip sockets, only the Red LED and chip in the upper right socket are used when configured for use in the PUPKIT. Both entry and exit boards are identical and can be interchanged. To test, momentarily jumper terminals V & 0 to operate the board. The Red LED should illuminate and the solenoid will energize (fail-lock, solenoid on terminals L & 0) or de-energize (fail-safe, solenoid on terminals S & 0). These boards can be either the TCB 6.0 or TCB 6.1 with PUPKIT configuration.

Please read the “Operation” section of this manual for a full understanding of the behavior before troubleshooting.

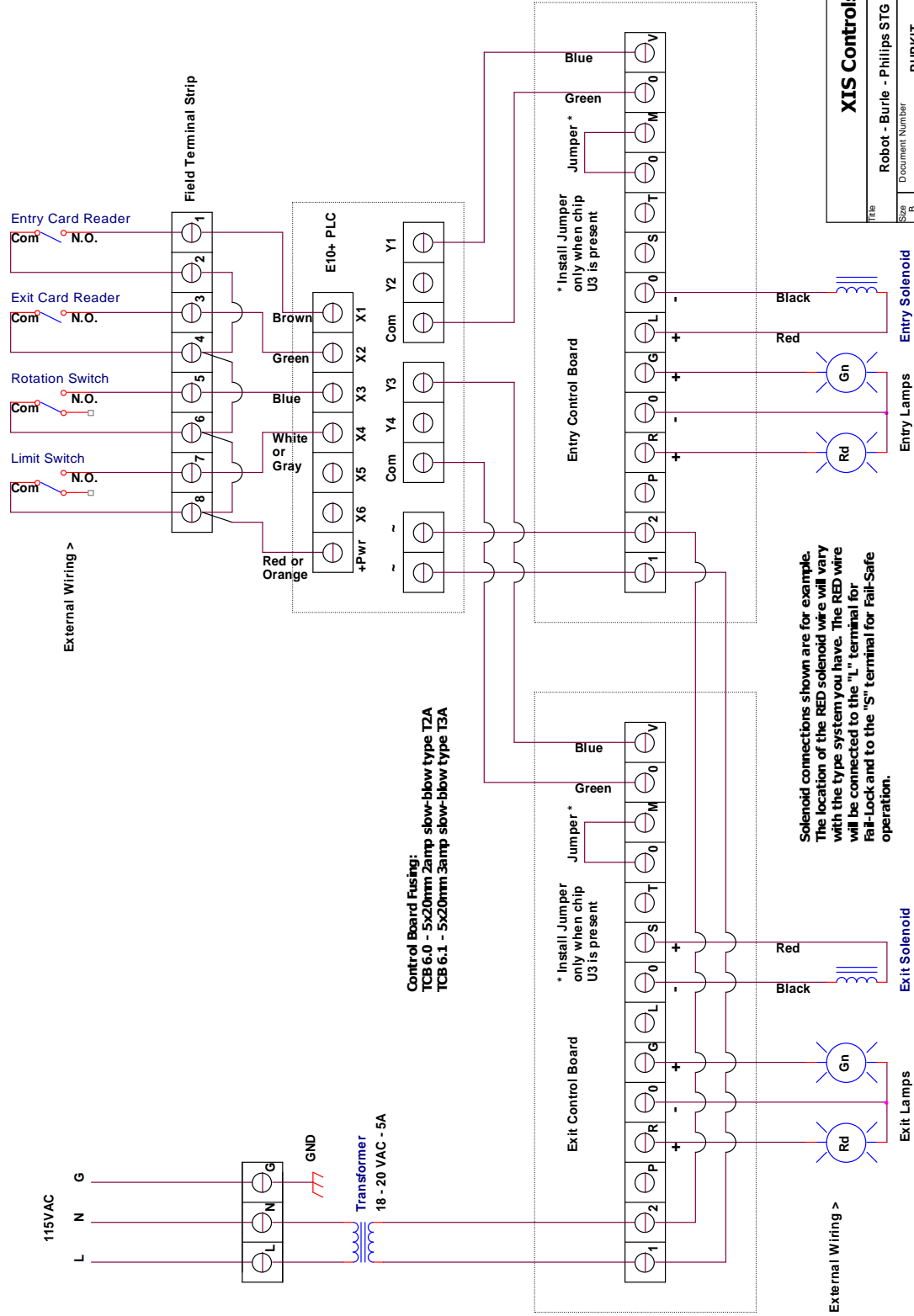

XIS Controls			
Robot - Burie - Philips STG Control Upgrade			
File	Document Number	Rev	2
Size	PUPKIT	Sheet	1 of 1
Date	Monday, July 04, 2011	Sheet	1 of 1