

100/200 Series
100/200SS Series
Waist-High Turnstiles

Installation and
Operating Instructions

Philips
Communication
Security & Imaging



PHILIPS

CONTENTS

UNPACKING YOUR TURNSTILE.....	2
INSTALLATION Dos AND DON'Ts.....	2
SITE PREPARATION.....	2
MOUNTING THE TURNSTILE.....	3
MANUAL.....	3
ELECTRICAL.....	3
COUNTER.....	4
KEY BYPASS.....	4
ELECTRICAL METHOD OF OPERATION.....	4
MAINTENANCE.....	5
RECOMMENDED SPARE PARTS.....	5
MOUNTING DIMENSIONS DRAWING.....	
FAIL-LOCK DRAWING.....	
FAIL-SAFE DRAWING.....	

UNPACKING YOUR TURNSTILE

Carefully unpack the turnstile from its shipping carton. Remove the small carton secured to the turnstile and check to ensure that the following items have been received:

1. Two cover keys.
2. Four Qwik bolt anchors.
3. Any accessories that have been ordered (pushbutton, card readers, etc).

Note: Check to ensure no damage has occurred in transit. If any damage is found, notify the carrier immediately. **Do not** proceed with unpacking.

After unpacking and before proceeding with the installation, check the packing and material check list. Verify that all equipment and any accessories ordered have been supplied.

INSTALLATION DOs AND DON'Ts

- DO..... Read all instructions thoroughly before proceeding with the installation.
- DO..... Pay special attention to all drawings when installing turnstile.
- DON'T... Service the turnstile without turning off the power.
- DON'T... Pre-set anchors

Caution

Improper installation WILL VOID all warranties on this product.

If you should have any questions or need more information, please contact our Technical Applications Department:

PHILIPS CSI, INC.
Access Control Hardware
7041 Orchard Street
Dearborn, MI 48126
Phone: (313) 846-2623
or (800) 338-3692
FAX: (313) 846-3569

SITE PREPARATION

It is **extremely** important that the turnstile be mounted on a solid and level foundation to avoid shifting and unstable operation.

If the site where the turnstile is to be mounted is without any foundation, it will be necessary to pour a concrete pad.

The turnstile must be mounted as illustrated on drawing 100/200-IB supplied.

MOUNTING THE TURNSTILE

The turnstile has been supplied with four (4) Qwik-bolt type anchors for securing the unit to its foundation. Do not pre-set the anchors.

1. Using an Allen wrench remove the screws holding the access panel in place.
2. Remove the panel so that the mounting holes and conduit space are visible.
3. Position the turnstile where it is to be permanently located making sure the unit is level. If applicable check to ensure any and all conduits are located in the access space provided.
4. When the turnstile has been positioned correctly trace the mounting holes with a colored pencil or magic marker. After marking the holes move the turnstile and prepare to drill the mounting holes.



Important: Always wear safety glasses. Follow the drill manufacturer's safety instructions. Use only solid carbide drill bits meeting ANSI B94 diameter standards.

5. Using a 3/8 in drill bit, drill the hole perpendicular to the work surface. Do not ream the hole or allow the drill to wobble.
6. Drill the hole deeper than the intended embedment.
7. Clean the hole, a clean hole is necessary for proper performance of the anchor bolt.
8. Assemble the washer and nut on the anchor so that the nut protrudes slightly beyond the head of the bolt. Using a hammer tap the anchor into the newly drilled hole until the washer and nut rest solidly against the concrete floor.
9. Tighten the nut 3 to 5 turns past the hand tight position. Once the anchor is firmly secured loosen and remove the nut and flat washer from the bolt.
10. Repeat the above procedure for the required amount of anchors.
11. Reposition the turnstile over the anchors and assemble the washers and nuts onto the bolts. Check to ensure the turnstile remains level while tightening each anchor. Make sure the turnstile has been fastened securely to its foundation.

MANUAL

All manual type turnstiles are ready for immediate operation. The turnstiles have been factory tested and no adjustment is necessary.

One-Way Manual

This model of turnstile rotates freely in one direction only. The direction (clockwise/counter-clockwise) is specified by the customer at time of order.

Upon receipt of turnstile check to ensure proper rotation.

Two-Way Manual

This model of turnstile rotates freely in both directions.

ELECTRICAL

If electrical turnstiles have been supplied it will be necessary to provide both power and control wiring to each unit prior to operation.

The turnstile has been thoroughly tested prior to shipment. All portions of the electrical circuit were checked to ensure proper operation.

For ease of installation all electrical models are pre-wired as much as possible at the factory. A complete wiring schematic is located inside the turnstile housing. Make sure the wiring schematic remains with the turnstile.

The power and control wires should be in separate conduits and brought up through the access spaces located in the bottom of the turnstile housing.

All field wiring is represented by dashed lines on the wiring diagram. Make sure all connections from external devices are made to the correct terminal points.



Important: Make sure power supply is the "correct" voltage, phase and cycle.

COUNTER (OPTIONAL)

When supplied with either the electric or manual turnstile the counter will be mounted and wired into the turnstile housing.

The counter is a self contained battery operated unit that is ready for immediate operation after turnstile installation.

The counter registers one count every time the arms of the turnstile rotate 120° in a specific direction. The counter is activated by a micro switch mounted on the turnstile mechanism. When the arms rotate the micro switch is tripped and provides a contact closure to the counter. This contact closure provides the necessary input signal to increment the counter.

The counter can be reset from the front panel button or remotely. Reset selection depends upon specific wire combinations.

Refer to the counter instructions located inside of the mechanism housing.

 **Important: No external power is required. Counter operates from two "N" type alkaline batteries. Battery life is approximately four years. Use only alkaline batteries with counters. "Do Not" use carbon-zinc batteries.**

KEY BYPASS (OPTIONAL)

If supplied with manual type turnstile this optional feature prevents the arms from rotating in a specific direction. This is accomplished mechanically, utilizing the key cylinder and accompanying linkage.

Note: A key by-pass must be ordered for each direction to be controlled.

If supplied with an electric turnstile the key by-pass option can be used to either lock up a specific direction of rotation or unlock (free-wheel) a specific direction.

ELECTRICAL METHOD OF OPERATION

Upon receipt of a **momentary contact closure,(must be 1 second or less)**, at the turnstile a control relay is activated. The control relay will then energize (fail-secure) or de-energize(fail-safe) the locking solenoid. This will disengage a locking bar from the ratchet assembly and allow the turnstile to rotate in the specified direction. As the turnstile arm rotates, a micro switch is tripped which de-energizes the control relay and allows the locking solenoid to return to its original state.

 **Important: Contact closure,(must be 1 second or less), must be a momentary type! Anything other than a momentary closure will result in multiple rotations.**

MAINTENANCE

As with any electrical or mechanical device, a scheduled maintenance program should be implemented to assure long, trouble-free operation.

This chart can help to determine when each item on the turnstile should be inspected and serviced.

Caution

Always disconnect power supply before servicing turnstile.

RECOMMENDED SPARE PARTS

(Refer to assembly drawings for part location.)

61-154	Spring
61-510	Roller (3)
61-512	Post
*61-515	Solenoid (specify voltage)
*61-534	Switch
*61-535	Actuator
62-514	Homing Cam Follower Assembly
62-515	Speed Control Cam Follower Assembly
63-133	Spring
85-214	Spring
85-278	Spring

*Applies to electrical models only.

Month Interval		1	3	6	12
Springs	Check tension	X			X
Relay & Solenoid	Check & test	X			X
Rollers (3)	Inspect for wear	X			X
Bearings	Lubricate		X		X
Arms	Check for looseness		X		X
Locking Cam & Post	Clean and lubricate		X		X
Speed Cylinder	Check			X	X
All Bolts	Check & tighten			X	X
Electrical	Inspect wire connections			X	X
Limit Switch	Check for wear			X	X
Arm Hub & Dowel Pin	Check for looseness and wear			X	X
Total Unit	Complete check			X	X

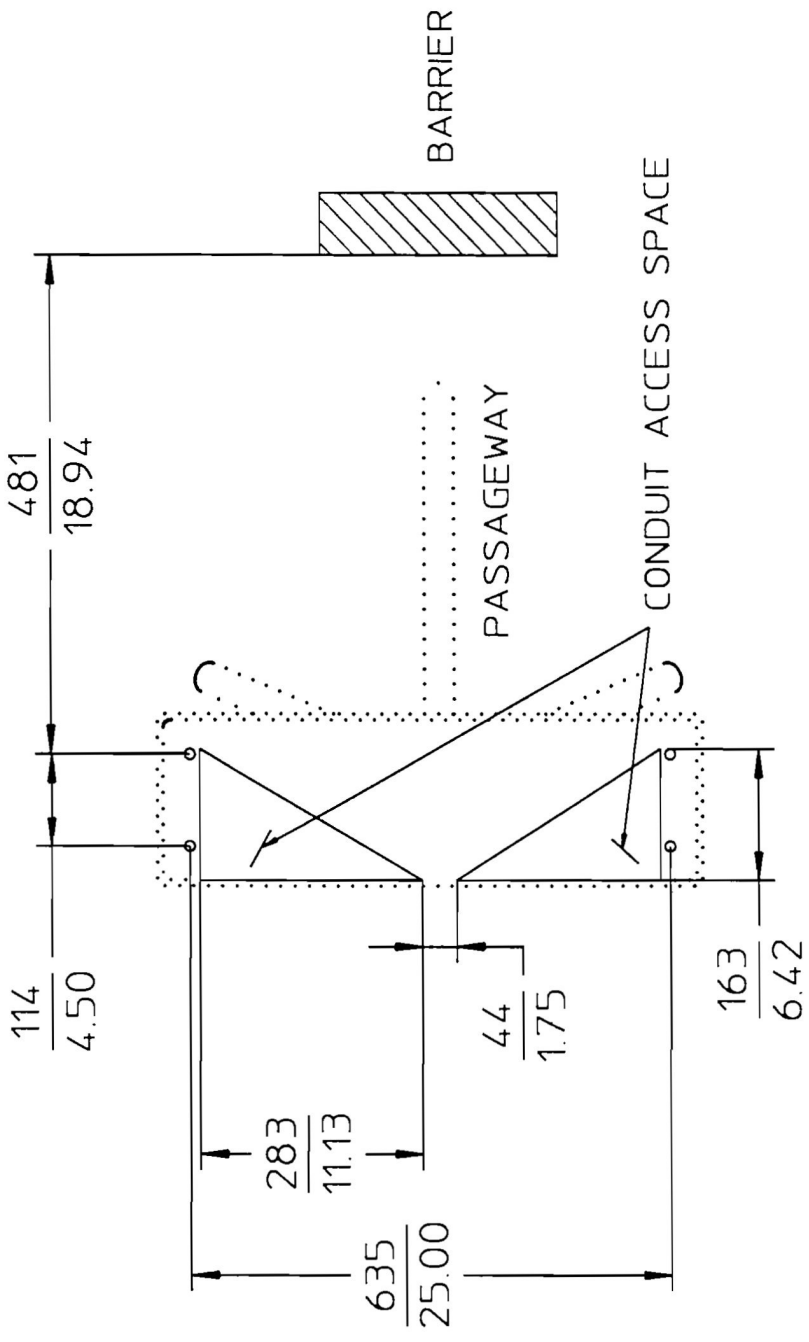

PHILIPS ACCESS CONTROL HARDWARE DIVISION
7041 ORCHARD, DEARBORN, MI. 48126

DRAWING TITLE:
100/200 MOUNTING DIMENSIONS

SIZE: MODEL: 100/200

REVISIONS: DRAWING NUMBER: 100/200-IB REV. 0

ALL DIMENSIONS ARE IN INCHES UNLESS SPECIFIED	
TOLERANCE UNLESS SPECIFIED	CLP 03/03/99
0.0 ± 0.060	
0.00 ± 0.030	
0.000 ± 0.015	
0.0000 ± 0.0005	
ANGULAR ± 0.5°	

REV.	DESCRIPTION	BY	DATE
1		***	##/##/##

THESE DRAWINGS & SPECIFICATIONS ARE THE PROPERTY OF AND PROPRIETARY TO PHILIPS INDUSTRIES, INC. AND ARE NOT TO BE DISCLOSED, REPRODUCED, COPIED OR USED AS THE BASIS OF MANUFACTURE OR SALE OF APPARATUS AND/OR DEVICES, OR OTHERWISE WITHOUT PHILIPS' PRIOR WRITTEN CONSENT.

CHECKED BY/DATE: JVB 03/03/99

SCALE: 1 : 15 ASSEMBLY

CAGE OBRM4 SHEET: 1 OF 1

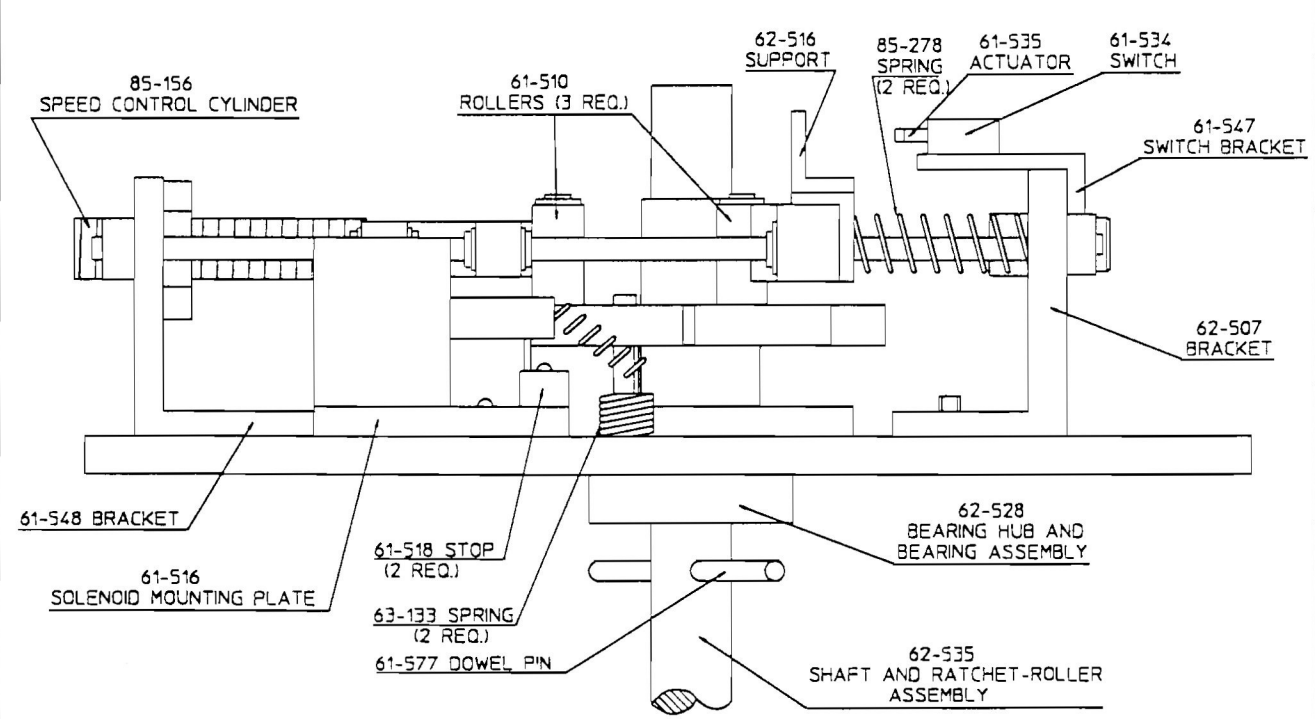
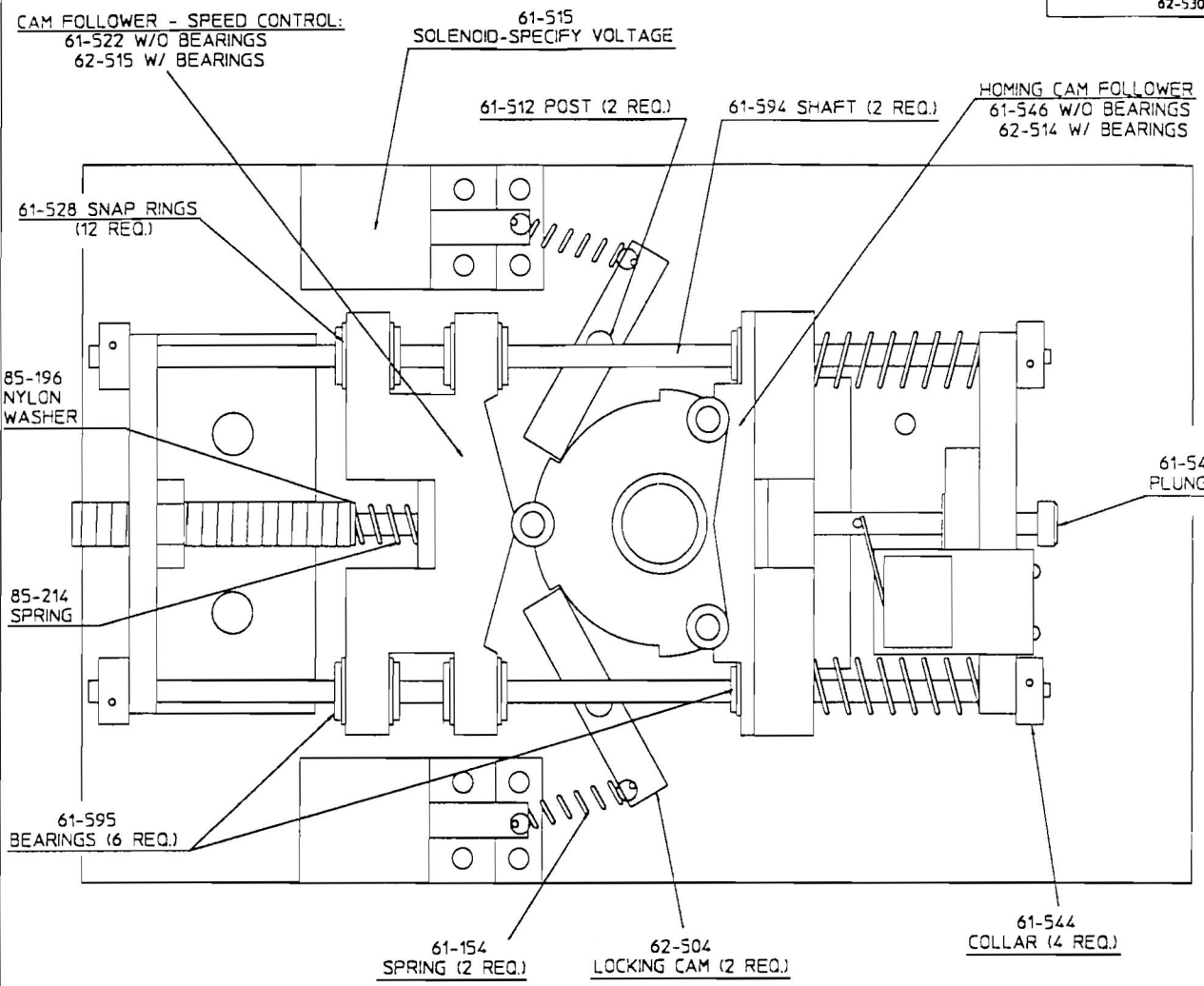

REVISIONS			ALL DIMENSIONS ARE IN INCHES UNLESS SPECIFIED		PHILIPS ACCESS CONTROL HARDWARE DIVISION 7041 ORCHARD, DEARBORN, MI 48028
REV.	DESCRIPTION	BY	DATE	TOLERANCE UNLESS SPECIFIED	
1	85-156 WAS 81-156	NAV/K/S/PS	NAV/12/79	0.00 ± 0.008 0.00 ± 0.030 0.008 ± 0.015 0.008 ± 0.005 ANGULAR ± 0.5°	DRAWING TITLE: FAIL-SAFE MECHANISM ASSEMBLY DRAWING
2	61-595 WAS 61-527 & 61-594 WAS 61-543				
DESIGNED BY/DATE			CHECKED BY/DATE		DATE PLOTTED: 0 LT
DRAWING NUMBER: 62-530			DRAWER ALPHABET		REV: 2

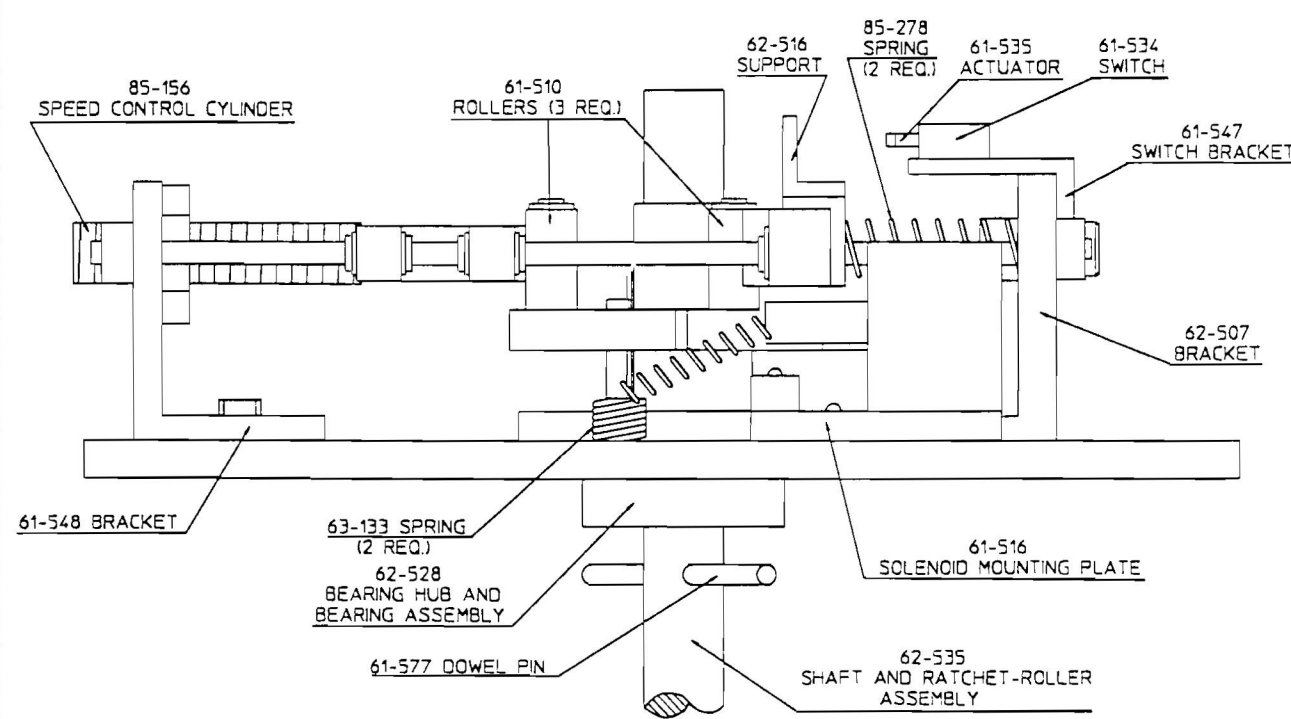
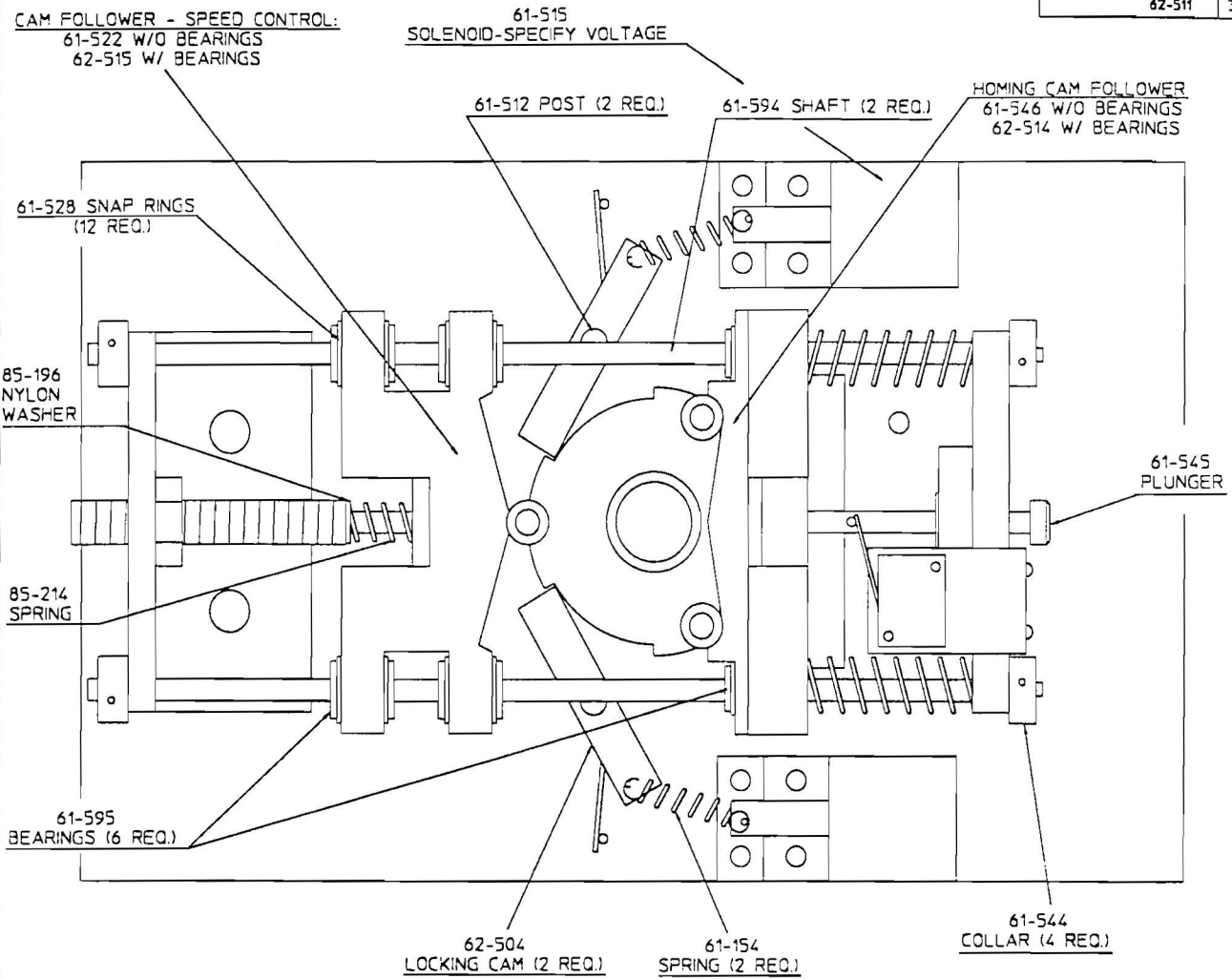

REVISIONS		DATE		TOLERANCE UNLESS SPECIFIED		DRAWING TITLE	
REV	DESCRIPTION	BY	DATE	INCHES	MILLIMETERS	SIZE	MODEL
1	CHANGED POSITION OF SPRING (P/N 61-154)	MAV/10/79	10/79	0.005	0.040	D	LT
2	SPACERS REMOVED, 85-156 WAS 81-156	MAV/16/79	16/79	0.000	0.015		
3	61-595 WAS 61-527 & 61-594 WAS 61-543	MAV/17/79	17/79	0.0100	0.005		
				ANGULAR	0.3°		

DESIGNED BY/DATE:
 CHECKED BY/DATE:
 ALL DIMENSIONS ARE IN INCHES UNLESS SPECIFIED
 TOLERANCE UNLESS SPECIFIED
 PHILIPS ACCESS CONTROL HARDWARE DIVISION 7611 GRAYLAND DEARBORN, MI 48024
 DRAWING TITLE: FAIL-LOCK MECHANISM ASSEMBLY DRAWING
 SIZE/MODEL: D LT
 DRAWING NUMBER: 62-511
 REV: 3